



DRILLING IN MENENGAI HIGH TEMPERATURE FIELD – DRILLING EQUIPMENT AND WELL DESIGN

Abraham Khaemba

Geothermal Development Company Ltd.

P.O. BOX 17700-20100, Nakuru

KENYA

akhaemba@gdc.co.ke

ABSTRACT

Drilling in the Menengai high temperature geothermal field has been on-going since early 2011, February 2011 when the first well, MW01 was spud in. total of seven 2000HP rigs are currently drilling in Menengai with one top holing rig used to top hole wells to anchor casing depth of between 400-500m. Three (3) of the seven rigs are still under commissioning. For the top holing, Atlas Copco predator 200 Klbs rig is used. The wells design for the Menengai wells is a regular well design with hole sections of diameter; 26", 17½", 12¼" and 8½". The hole sections are cased with casings of diameter 20", 13¾", 9¾" and 7" slotted liners which are set inside the 9¾" casings. Both vertical and directional wells have been drilled with the kick off point for the drilling wells below the anchor casing in the 12¼" hole section.

1. INTRODUCTION

Structures in Menengai Geothermal Field, shown in Figure 1 are majorly controlled by two tecto-volcanic systems namely Molo and Solai structural systems. Tecto-volcanism involved a mix of intense faulting and volcanism giving rise to major fracture systems that enhanced highly permeable zones, suitable for geothermal resource exploration. The Volcano's caldera collapsed and concentrated tectonic grid faulting (block and fissure faults) in northern Menengai characterized by extension faulting associated with spreading (rifting) at crustal boundaries. The Molo TVA is older than the Solai system which cuts into the Caldera. The floor of Menengai is covered by several post-caldera lava flows (Kahiga 2014). Sub surface studies of apparent resistivity, hydrothermal alteration mineralogy and well temperatures been utilized to characterize the system and thus for design of wells (Noor Y, et al, 2012). The system shows three (3) distinct regions:

- At shallow depths less than 200m show high resistivity(>1000Ωm), showing a low temperature zone of temperatures below 40° C. it's a region of negligible hydrothermal alteration with cold un altered rocks.
- At depths of 400-800m, region of low resistivity (<20Ωm), with moderate temperatures up to 200°C. The region has moderate hydrothermal alteration and resulting in formation of conductive clays with high conductivity which form the cap rock for the system.
- Below 800m, to the bottom of wells at 2500m, resistivity increases gradually to moderate resistivity of (<45Ωm), correlating with high temperature formation above 240°C which forms the production zone for wells drilled in the field.

2. WELLS DRILLED

Below is a summary of wells drilled in the Menengai geothermal field by November 2015:

- 23 vertical wells drilled;
- 11 directional wells drilled; and
- 8 top holed wells drilled to the anchor casing.

Figure 2, below shows location of wells that have been drilled in the Menengai geothermal field.

Wells enclosed by the black rectangle shows completed production wells that have been drilled for the first phase of generation. Wells in the blue rectangle show wells for the second phase of production. Some of the wells have been completed, some are currently being drilled while other have been top holed to anchor casing. On the out skirts of the caldera, step out wells have also been drilled.

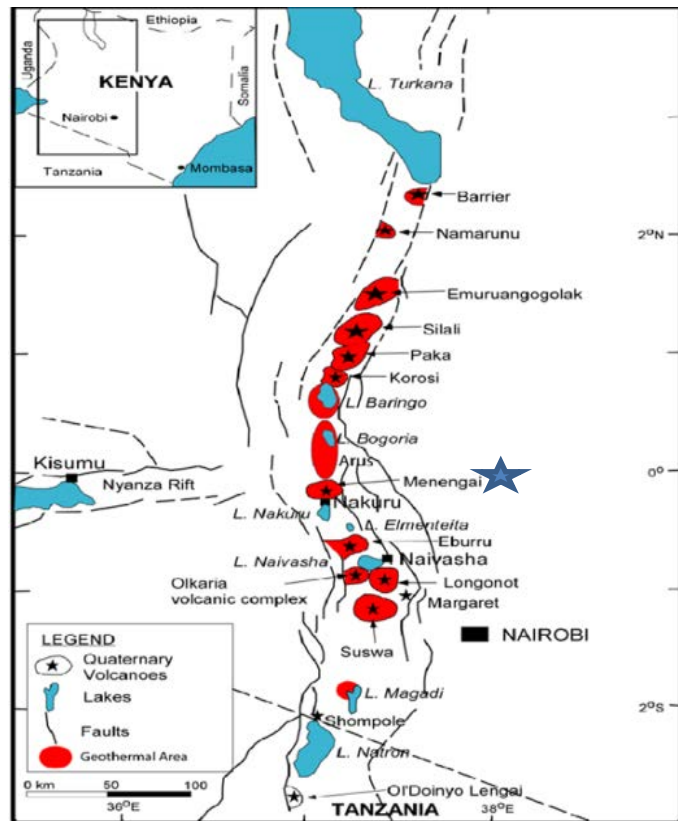

FIGURE 1: Location of Menengai

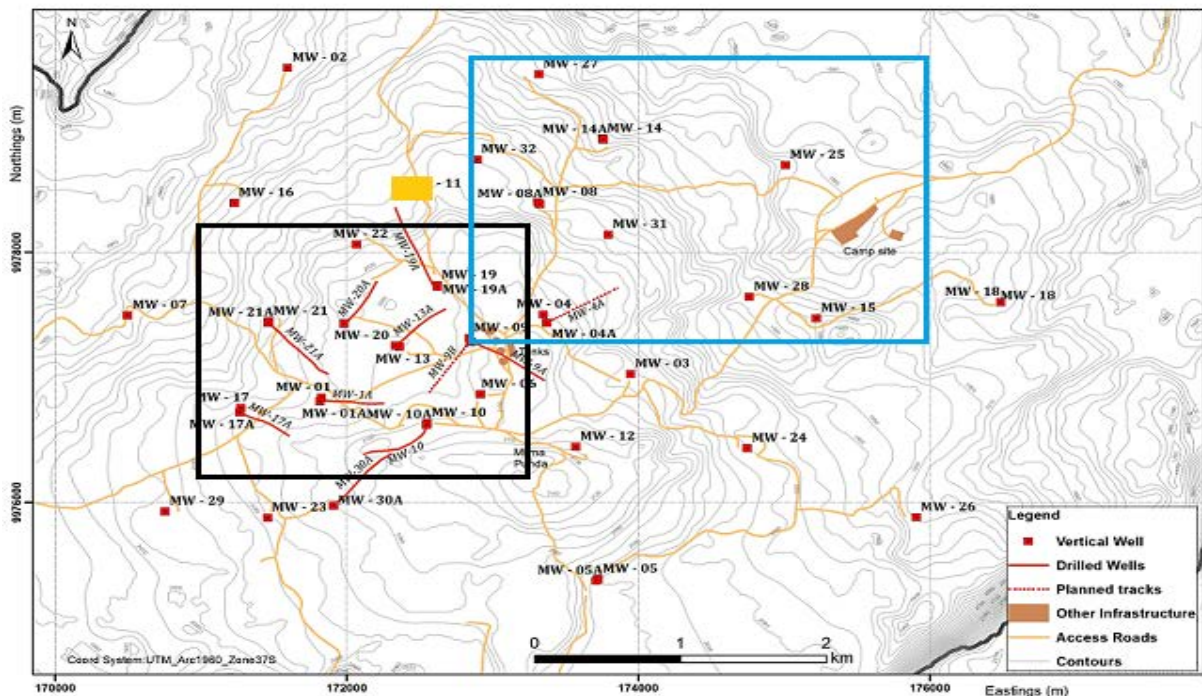

FIGURE 2: Wells drilled in Menengai geothermal field

The design of wells is:

- The conductor casing of diameter 30" which is driven to ground to about 3m.

- 26" diameter hole is drilled to 80m, then cased with 20" surface casing and cemented back to the surface.
- 17½" diameter hole is drilled to a depth of 400m. The 13¾" anchor casing is run and cemented back to the surface. Top holed wells are drilled up to this section.
- 12¼" diameter hole is drilled to between 800-1400m, the 9-5/8" production casing is run and cemented back to surface. The kick off point for the directional wells is in this section about 20m below the casing shoe.
- 8½" production section is drilled to TD (total depth) of 2500-3000m. A slotted 7" liner is then placed at the bottom of the 9 5/8" casing with a liner hanger and it stretches down to the bottom of the production section.

3. RIG EQUIPMENT

3.1 Top holing rig

For the top holing, an Atlas Copco predator rig shown in Figure 3 is used. The predator drilling system comprises of three (3) components; mobile rig, substructure and pipe skate. Fluid circulation system consisting of mud tanks, mud pumps and air drilling package has been encompassed for drilling of geothermal wells.



FIGURE 3: Atlas Copco predator rig

Advantages of using the top holing rig are:

- There is reduction on non-drilling time and cost by improving mobility and reducing rig up time;
- Enhanced safety by reducing rig crew, manual labour, using hands free pipe and casing handling and a simple, precise and on demand control system;
- Improved drilling performance due to the hydraulic systems power and speed with the hammer bit for challenging environments;
- Lower operating costs as the system utilizes less power reducing fuel cost; and
- Less environmental impact due to the reduced foot area of the rig.

The top holing rig has only capacity to run 9½" casings to 1100m. Since most wells in Menengai have their production casing deeper at 1200m, the rig is used to drill and case to 13¾" anchor casing. Table 1 shows the specifications of the predator rig.

TABLE 1: Predator rig specifications

PREDATOR RIG SPECIFICATIONS		
	US	Metric
Hook load capacity	100 tons/200,000 lbs	91 tons/ 90,718 kgs
Top drive Hydraulic	Licenced API 4F 3rd Edition	
High torque range	30.000 lbf-ft	40.7 KNm
	0-90 rpm	0-90 rpm
High speed range	15,000 lbf-ft	20.3 KNm
	0-180 rpm	0-180 rpm
Spindle ID	5 Inches	127 mm
Telescoping Mast	Licenced API 4F 3rd Edition	
Hydraulic carriage Feed system	180 ft/min	54m/min
Single engine power	950 HP	373 KW
Custom carrier hydraulic drive	500 HP	373 KW
Substructure with BOP house	Licenced API 4F 3rd Edition	
Rated capacity	100 tons/200,000 lbs	91 tons/90,718 Kgs
Wok floor	220 ft ²	20.4M ²
Removable table clear opening	44 Inches	1118 mm
Bare table opening	27½ Inches	699 mm
Master bushing (Slip assembly)	17½ Inches	44.5 mm
Hands free breakout system	Hydraulic slips and iron roughneck	
Pipe capacity	Range II and range III	
Pipe stotage	Two fold out pipe racks	

3.2 2000HP SCR land rig

The rig comprises of six distinct systems:

1. Hoisting system. Primary function is to support, lift and lower rotating drill string while drilling is in progress. Consists of supporting structure (mast, substructure and rig floor) and hoisting equipment which includes the Drawworks, crown block, travelling block, hook, links, elevators, and the drilling line.
2. Power system. Consist of prime mover, primarily diesel engines and means of transmitting power to the auxiliary equipment. Transmission may be in the form of mechanical drives like chains, DC generators and motors or AC generators, SCR (Silicon control rectifiers), DC motors.
3. Circulation system. Consists of pumps, standpipe, rotary hose, swivel, Kelly, drill string, shale shakers, tanks and mud pits and its mainly used to clean cuttings from the well bottom.
4. Rotary system. It's responsible for imparting a rotating action to the drill string and bit, main components are the Kelly, rotary hose and drill string. In top drive systems, the top drive provides the drive.

5. BOP system. The blow out preventer (BOP) is used to seal the well to prevent uncontrolled flow or blowout of formation fluids. Consists of annular preventer, drill pipe or casing rams and blind rams and an accumulator system.
6. Auxiliary rig equipment. Include additional items added to the rig which include drill string handling tools, instrumentation system, air hoists and rig floor tools. The rig is shown in Figure 4.

The specifications for the 2000HP rig include:

- Nominal depth range of 5000 m;
- Maximum pull on 12 lines of 5000 klbs;
- Drilling line size of 1½" diameter;
- Mast
 - Maximum wind load of bare mast is 179 km/hour;
 - Maximum wind load full pipe pipe setback 129.6 km/hour;
 - Maximum static hook load (12 lines) is 500 US tons;
- Substructure
 - Floor height of 34.5 feet;
 - Clear height, 30 feet;
 - Rotary capacity, 500 US tons;
 - Set back capacity, 300 US tons;
- Travelling block and swivel
 - Max hook load for travelling block – 450 tons;
 - Max static load of swivel is 450 tons;
- Rotary table
 - Hole opening 37½ inch;
 - Maximum static load is 500 US tons;
- Mud pumps
 - 3 units with 7 inch liners;
 - Make F-1600;
 - Maximum output per mud pump is 5.99 gallons per second or 226 litres per second;
 - Maximum pressure is 3345 Psi; and
 - Maximum strokes per minute is 120.

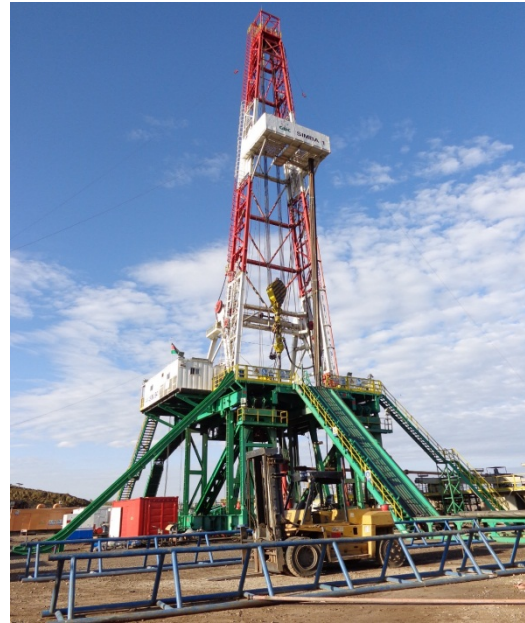

FIGURE 4: 2000 HP SCR land rig
(Atlas Copco, 2011)

3.3 Comparison of drilling 20" and 17½" sections for the two rigs

Comparison was done of the average rate of penetration for wells in close proximity as indicated in Figure 2 of wells either drilled by the top holing rig or the 2000HP rig for the top two sections to anchor casing.

Plots of drilled depth against the number of drilling days were plotted as shown in Figure 5 and Figure 6.

Wells drilled by top holing rig:

- MW26 took 18 days to drill to 303 m (Average rate of penetration of 16.83 m/day);
- MW24A was drilled 24 days to 503 m (Average rate of penetration of 20.95 m/day).

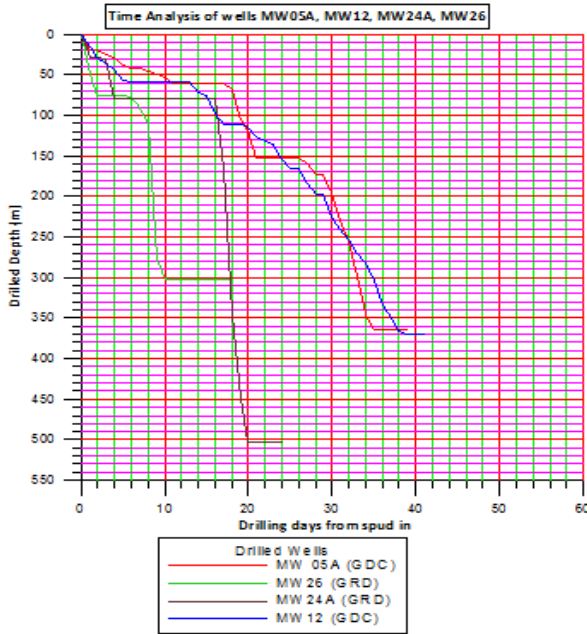

FIGURE 5: Comparison of wells drilled - 1

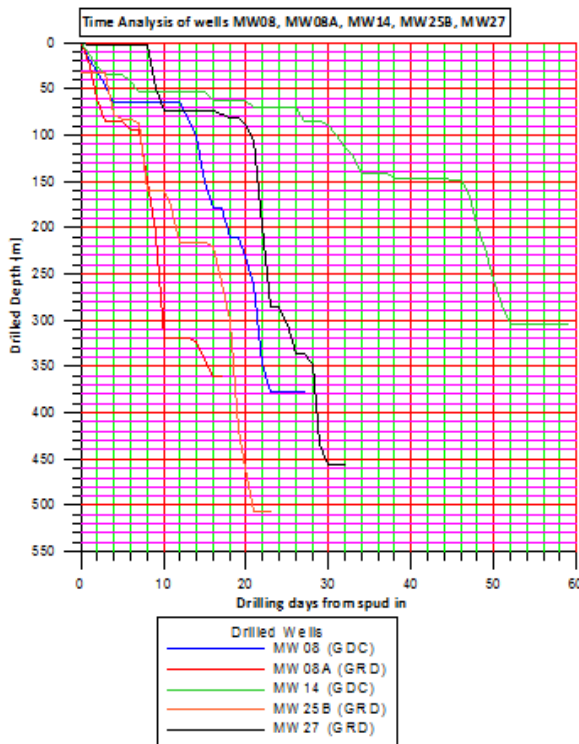

FIGURE 6: Comparison of wells drilled - 2

performance and recognition of drilling practices needed to ensure performance.

Design steps necessary to drill a deep well safely include:

- Taking geological and reservoir engineering advice on likely sub surface rock and fluid properties;
- Determining depths for casing and well completion;
- Selecting casing diameters, thicknesses, cementing materials and cementing programs;

Wells drilled by 2000HP land rig:

- MW12 took 42 days to drill to 369.35 m (Average rate of penetration of 8.79 m/day);
- MW05A took 39 days to drill to 364 m (Average rate of penetration of 9.33 m/day).

Wells drilled by the top holing rig:

- MW08A was drilled to a depth of 360 m in 17 days (Average rate of penetration of 21.18 m/day);
- MW25B was drilled to a depth of 507 m in 23 days (Average rate of penetration of 22.04 m/day); and
- MW27 was drilled to a depth of 456 m in 32 days (Average rate of penetration of 14.25 m/day).

Wells drilled by 2000HP land rig:

- MW08 took 27 days to drill to 378 m (Average rate of penetration of 14 m/day);
- MW14 was drilled to a depth 305 m in 59 days (Average rate of penetration of 5.17 m/day).

From the plots it can be concluded that the use of the top holing rig also increased the rate of penetration and thus reduces the number of days taken to drill the top two sections which had been problematic drilling with the large rig and thus saving costs.

4. WELLS DESIGN

4.1 Well design

Conditions to consider while designing wells at Menengai include; sub surface conditions to be encountered, equipment to be used, material performance and recognition of drilling practices needed to ensure performance.

- Deciding on drilling fluids, drill string assemblies and well heads; and
- Nominating necessary equipment, tools, materials, support facilities and site requirements.

Particular geological information required for well design includes:

- Rock type or formation, location of any specific stratigraphic marker beds.
- Compressive strengths, degree of consolidation.
- Faulting, fracturing and gross permeability.
- Effects of drilling activities on formation like swelling of water sensitive clays.

The wells drilled are either vertical wells or directional wells as shown in Figure 7. Directional wells have a kick off point at 400m, just below the anchor casing setting depth. Other considerations during design of Menengai wells include:

- BHA and drill string design;
- Drilling fluids;
- Casing program;
- Well cementing; and
- Well completions.

4.1.1 BHA and drill string design

For the bit to drill, it requires rotary motion. The drill string provides this rotation motion from the surface to the bottom of the hole. It provides the connection between the rig and the bit (Ngugi, 2008). The lower part of the drill string, is called the Bottom hole assembly (BHA). The main function of the BHA is to provide weight to be exerted on the bit for drilling. The drill string provides these functions:

- Provide the fluid conduits to the drill bit;
- Impart rotary motion to the drill bit;
- Provide and allow weight (force) to be set on bit; and
- Lower and raise the bit.

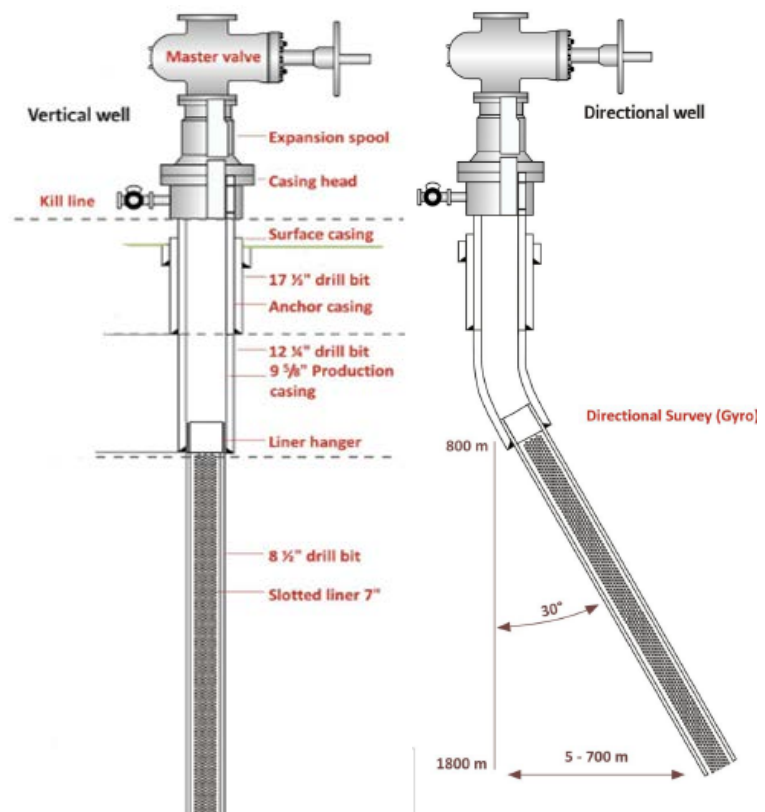

FIGURE 7: Vertical and directional well profiles

The different components of the drill string and their functions are:

- Bit sub/ NRV sub- Placed above the bit. It's used to connect the bit and the first collar. It has recess to accommodate the non-return valve that ensures the fluid does not flow backwards.
- Drill collar- stiff steel components about 10m, weighing 2 to 3.5 tons. They provide weight for the bit, strength needed to run in compression, minimizes vibrations, wobbling and jumping and also minimize directional control problems by providing stiffness to the BHA. Most commonly used collars are round (slick) and spiral grooved.
- Heavy weight drill pipes (HWDP)- Have weight 2-3 times the weight of drill pipe and offer a safer transition from drill collars to drill pipes therefore minimizing drill pipe failure.

- Drill pipes- Are the longest section of the drill string. Consist of tube body welded to two tool joints with male (pin) and female (box) threads. Most common sizes are 3½", 4½" and 5".
- Kelly saver sub- Fitted between the Kelly and drill pipe. It's a sacrificial tool to save the Kelly from wear arising from frequent connections.
- Kelly- Designed in a square or hexagonal shape. It's fitted into a Kelly drive bushing, with it, it imparts rotational motion on the drill string which is transmitted to the bit.
- Stabilizers- Run as part of the BHA. They provide stabilization to the BHA and for directional control.
- Jar- Run as part of the BHA, when drilling at deep depths to help free a stuck string.
- Positive Displacement Motor (PDM). Used for deviating while drilling directional wells to desired targets.

4.1.2 Drilling fluids

Primarily the drilling fluid removes the cuttings from the bottom of the hole as fast as they are created to facilitate efficient hole making process. The drilling fluid is pumped through the string to the bottom, then back to the surface through the annulus as shown in Figure 8. The returns are passed through the shakers to take out the cuttings then the fluids are reused. Other functions of the drilling fluids are:

- Cleaning of the hole bottom;
- Carry cuttings to the surface;
- Cool and lubricate the bit and drill string;
- Minimize formation damage;
- Control formation pressure;
- Maintain hole integrity;
- Assist in well logging operations;
- Minimize corrosion of drill string and casing;
- Minimize torque, drag and pipe sticking; and
- Cooling of the formation.

The basic properties of drilling fluids that are mostly important for successful drilling are: Density for controlling hydrostatic pressure, viscosity affects the efficiency of cuttings lifting capacity and filtrate loss property which determines the amount of water lost to the formation.

The annular velocity around the drill pipe is the lowest is used to determine if the velocity is good enough for hole cleaning.

For formations that are easily washed off, the annular velocity around the BHA tools is considered to reduce well bore erosion.

For unbalanced drilling for the 12¼" and 8½" hole sections foam drilling is used with annular velocity of 146.73ft/min for the 12¼" hole and 216.22ft/min for the 8½" hole. Drilling fluids used:

- 26" Surface hole- Bentonite mud with LCM. Water for drilling blind with mud sweeps.
- 17½" Intermediate hole- Bentonite mud with LCM. Water for drilling blind with mud sweeps. In extreme cases of poor hole cleaning stiff foam is used.

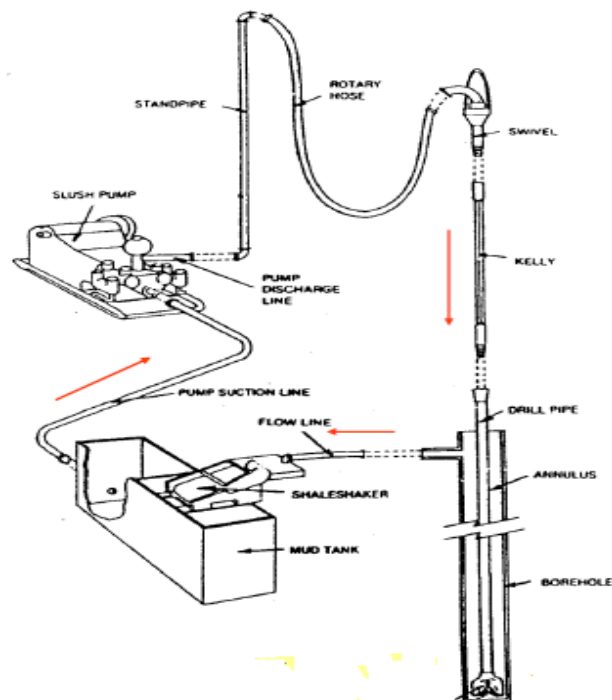

FIGURE 8: Drilling fluids system

- 12¼" Production hole- This section is drilled with mud and when mud circulation cannot be sustained, aerated water with foam is used.
- 8½" Main hole-Drilled entirely with water, and when signs of lost circulation occur, partial or total, aerated water with foam is used.

4.1.3 Casing program

These casing strings are run for the Menengai wells:

- Conductor casing: Run from the surface to shallow depth to protect near surface unconsolidated formations. The casing is 30 inch.
- Surface casing: Run to prevent caving in of weak formations that are encountered at shallow depths. It should be set in a competent rock. It should be deep enough to support the BOP for drilling to the anchor casing shoe depth. Its 20" in size
- Anchor casing: Protects surface aquifers against contamination during drilling. This casing supports the BOP and later the final production well head. Its 13¾" in size
- Production casing: Run to isolate producing zones and provide reservoir fluid control. Depth chosen on the basis of expected depth and the temperatures of fluids to be included and isolated. It conveys steam and water to the surface. Its 9½" in size
- Liner casing: 7 inch slotted liners that are run and set inside the production casing to allow fluid into the well bore.

Table 2 shows the different considerations during design of casing setting depth.

TABLE 2: Factors affecting casing loading (Southon, 2005)

STRESS	INSTALLATION	INJECTION	PRODUCTION
Collapse	Cement column outside and water inside the casing. Biaxial tensioning	Biaxial load	Trapped water in uncemented sections in annulus
Burst	Surface pressure to lift cement. Gas accumulation	Injection pressure. Gas accumulation and depression of water table	Well head pressure
Tension/ Compression	Cooling load. Support of own weight	Axial load due to cooling	Thermal expansion

4.1.4 Cementing procedure

For cementing of Menengai wells, single stage cementing method shown in Figure 9. The spacer is first pumped then followed by the cement slurry. The spacer provides barrier to avoid cement slurry mixing with mud. After the slurry volume calculated to be pumped has been pumped, the top plug is released and displacing fluid pumped. The volume of displacing fluid is calculated. Upon displacement of the cement in the casing and bumping the plug, float collar keeps the cement in place. If cement returns are

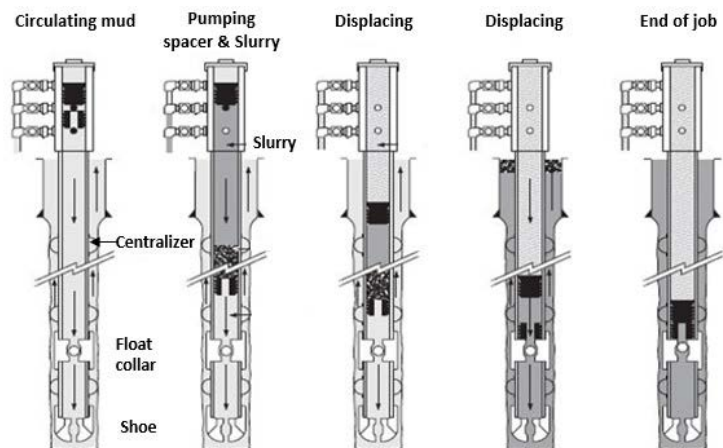

FIGURE 9: First stage cementing method (Nelson, 1990)

not received on surface after primary cementing, backfills are done through the annulus until cement returns are received on surface.

4.1.5 Cement slurry design

Slurry design is affected by well depth, bottom hole circulating temperature (BHCT), bottom hole static temperature (BHST), type of drilling fluid, slurry density, pumping time, quality of mix water, fluid loss control, flow regime, settling and free water, quality of cement and dry or liquid additives (Bett, 2010). Cement slurry performance properties tested before cementing are:

1. Thickening time; designed to determine how long cement slurry remains pumpable under simulated down-hole conditions.
2. Slurry density; should be specified to be high as possible throughout cementing interval without causing formation breakdown during placement.
3. Free water; tested to help determine the amount of free water that will gather on top of cement slurry between the time it is placed and the time it gels and sets up.
4. Fluid loss; is designed to measure slurry dehydration during and immediately after cement placement under simulated wellbore conditions. Slurry tested for filtrate loss.
5. Compressive strength; pressure it takes to crush the set cement is measured in this test. Test indicates how the cement sheath will withstand the differential pressures in the well.
6. Rheology testing; to properly predict the frictional pressures that will occur while pumping the various fluids in the well the rheological properties should be known as a function of temperature.

Portland cement is used for cementing wells at Menengai with these additives:

1. Retarders: Used to prolong thickening time to avoid the risk of cement setting prematurely inside the casing.
2. Lightweight additives (Extenders): Used to reduce the slurry density for jobs where the hydrostatic head of cement may exceed fracture gradient of formation.
3. Friction reducers (Dispersants): Added to improve flow properties of slurry. Lower friction and lower pressure during pumping enhancing turbulent flow at reduced pumping rates.
4. Fluid loss control additives: Used to prevent dehydration of cement slurry and premature setting.
5. Loss of circulation (LOC) additives: The additives help control the loss of slurry to the formation.
6. Antifoam additives: Used to decrease foaming and minimise air entrapment during mixing. Excessive forming can result in an underestimation of density down hole.
7. Accelerators: Added to cement slurry to shorten setting time. Used for surface casing and cement plugs.

4.1.6 Well capping

After completion of drilling, well completion tests are carried out before the final well head (master valve) is installed on the well. The tests allow for an early assessment of the likely production or injection capacity of the well. Well completion tests involve:

- Spinner test. This is used to identify the location of the permeable zones within the well and to quantify the relative permeability of each of the zones identified. The spinner tool also measures and records the down hole temperature and pressures.
- Water pumping test to obtain Injectivity and thus the gross permeability of the well.
- Casing condition survey to obtain an initial graphical image of the casing in the well.

After completion of the tests the well is capped with a 10 inch gate valve (Master valve). Three classes of master valves are used, Class 600, 900 or 1500.

REFERENCES

Atlas Copco, 2011: *The predator drilling system*. Atlas Copco Oil and Gas Rigs.

Bett, E.K., 2010: *Geothermal well cementing, materials and placement techniques*. Report 10 in: *Geothermal training in Iceland 2010*. United Nations University Geothermal Training Programme, Reykjavík, Iceland, 99-130.

Kahiga, E., 2014: Significance of tectono-volcanic axes in Menengai Geothermal Field. *Proceedings of the 5th African Rift Geothermal Conference*, Arusha, Tanzania, 10 pp.

Nelson, E.B., 1990: *Well cementing*. Schlumberger Educational Services, Texas, United States, 487 pp.

Noor, Y., Suwai, J., and Kangogo, D., 2012: Correlating resistivity with temperature and alteration mineralogy in Menengai Geothermal Field: Case study of Menengai exploration well (MW01). *GRC Transactions*, 36, 731-736.

Southon, J.N.A., 2005: Geothermal well design, construction and failures. *Proceedings of the World Geothermal Congress 2005*, Antalya, Turkey, 6 pp.